

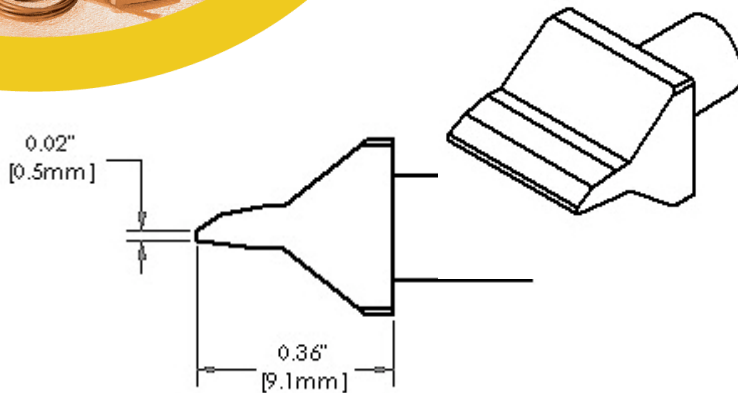

New Product Introduction

Metcal SMTC High Mass Blade Tips



OK International is pleased to announce a new range of high mass SMTC blades which utilize the available power from the MX-5000 delivering a safer cleaning process and reducing the risk of damage to solder resist. These tips were developed by increasing mass on tip without increasing temperature. The range includes length sizes of 5mm, 10mm, 15mm, 25mm and 35mm, and is available in 600, 700 and 800 series.

New Product Intro

Part Number		Part Number	
SMTC-xBL050		SMTC-xBL100	
SMTC-xBL150		SMTC-xBL350	
SMTC-xBL250			

NOTE: These new tips have been designed specifically for use with the MX-5000. Due to the lower available power, blades longer than 15mm are not suitable for use on MX-500 systems.